

RPN 0700-1.R DOOR LUG - 40 WIDE

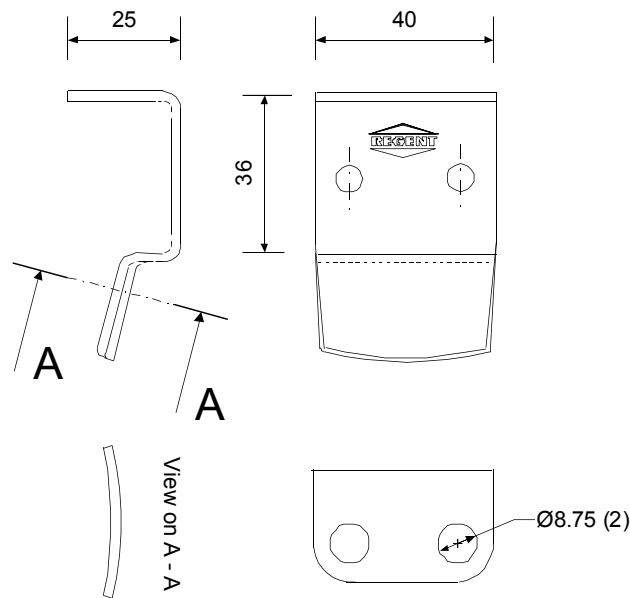

Material - Low carbon Steel to EN 10130 FePo4 - 2.0mm Thick
Finish - Self Colour

RPN 0716-9 DOOR LUG - 20 WIDE

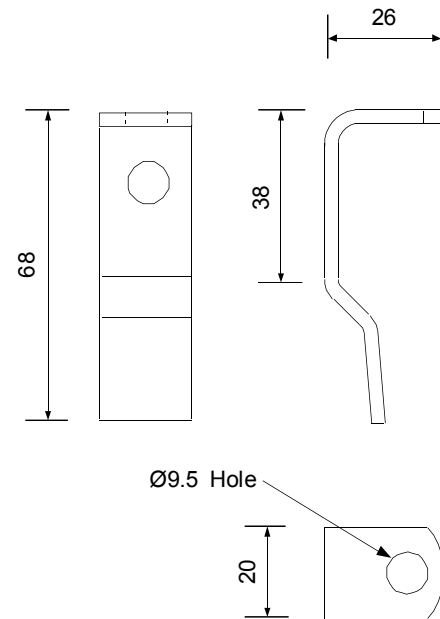

Material - Low carbon Steel to EN 10130 FePo4 - 3.0mm Thick
Finish - Self Colour

RPN 0316 ST. DOOR LUG - 20 WIDE

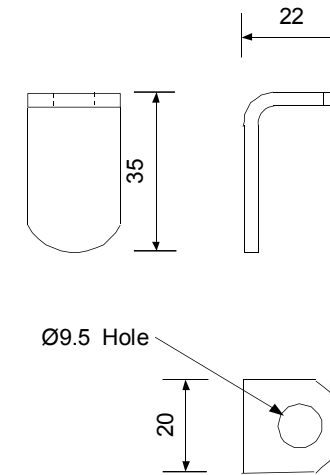

Material - Low carbon Steel to EN 10130 FePo4 - 3.0mm Thick
Finish - Self Colour

All dimensions in Millimetres

The Regent Engineering Co. (Walsall) Ltd Salisbury Street Darlaston Wednesbury West Midlands WS10 8XB UK

E-mail : info@regenteng.com

Web : www.regenteng.com

Phone 44 (0)121 526 6060

Fax : 44(0)121 526 4789

© 2012